

The PT7750 series is a +24V input, 15 Amp output, high-performance Integrated Switching Regulator (ISR) housed in a 27-pin SIP package. The 15A capability allows easy integration of the latest high-speed, low-voltage  $\mu$ Ps and bus drivers into +24V distributed power systems.

The PT7750 series has been designed to work in parallel with one or

more of the PT7747 current boosters for increased  $I_{out}$  in increments of 15A.

The output voltage of the PT7750 series can be easily programmed over a wide range with a 5-bit input. A differential remote sense is provided which automatically compensates for any voltage drop from the ISR to the load.

2000 $\mu$ F of output capacitance is required for proper operation.

### Standard Application

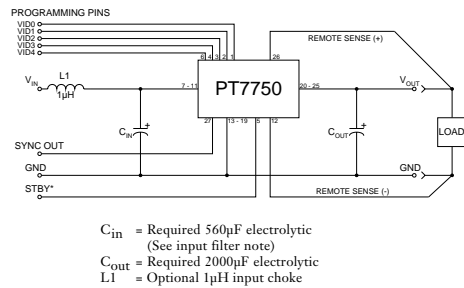

### Pin-Out Information

Pin	Function	Pin	Function
1	VID0	14	GND
2	VID1	15	GND
3	VID2	16	GND
4	VID3	17	GND
5	STBY* - Stand-by	18	GND
6	VID4	19	GND
7	V <sub>in</sub>	20	V <sub>out</sub>
8	V <sub>in</sub>	21	V <sub>out</sub>
9	V <sub>in</sub>	22	V <sub>out</sub>
10	V <sub>in</sub>	23	V <sub>out</sub>
11	V <sub>in</sub>	24	V <sub>out</sub>
12	Remote Sense Gnd	25	V <sub>out</sub>
13	GND	26	Remote Sense V <sub>out</sub>
		27	Sync Out

For STBY\* pin:  
open = output enabled  
ground = output disabled.

### Features

- +24V bus input
- High Efficiency
- Differential Remote Sense
- 27-pin SIP Package
- Paralleable with PT7747 15A current boosters

### Specifications

Characteristics (T <sub>a</sub> = 25°C unless noted)	Symbols	Conditions	PT7750 SERIES			Units	
			Min	Typ	Max		
Output Current	I <sub>o</sub>	T <sub>a</sub> = +60°C, 200 LFM T <sub>a</sub> = +25°C, natural convection	0.1 (1)	—	15 (2)	A	
Input Voltage Range	V <sub>in</sub>	0.1A ≤ I <sub>o</sub> ≤ I <sub>o</sub> max	20.0	—	28.0	V	
Undervoltage Lockout Threshold	V <sub>uvl</sub>	0.1A ≤ I <sub>o</sub> ≤ I <sub>o</sub> max	—	18.7	—	V	
Output Voltage Tolerance	ΔV <sub>o</sub>	V <sub>in</sub> = +24V, I <sub>o</sub> = 15A PT7751 0°C ≤ T <sub>a</sub> ≤ +55°C PT7756	—	—	±80 ±160	mV	
Line Regulation	Reg <sub>line</sub>	20V ≤ V <sub>in</sub> ≤ 28V, I <sub>o</sub> = I <sub>o</sub> max (w/remote sense)	—	±15	—	mV	
Load Regulation	Reg <sub>load</sub>	V <sub>in</sub> = +24V, 0.1 ≤ I <sub>o</sub> ≤ I <sub>o</sub> max (w/remote sense)	—	±10	—	mV	
V <sub>o</sub> Ripple/Noise	V <sub>n</sub>	V <sub>in</sub> = +24V, I <sub>o</sub> = I <sub>o</sub> max	—	75	—	mV	
Transient Response with C <sub>out</sub> = 2000 $\mu$ F	t <sub>tr</sub>	I <sub>o</sub> step between 7.5A and 15A V <sub>o</sub> over/undershoot	—	100	—	$\mu$ Sec	
	V <sub>os</sub>		—	200	—	mV	
Efficiency	$\eta$	V <sub>in</sub> = +24V, I <sub>o</sub> = 10A	V <sub>o</sub> = 5.0V	—	88	—	%
			V <sub>o</sub> = 3.3V	—	84	—	
			V <sub>o</sub> = 2.5V	—	80	—	
Switching Frequency	f <sub>o</sub>	20V ≤ V <sub>in</sub> ≤ 28V 0.1A ≤ I <sub>o</sub> ≤ 15A	300	350	400	kHz	
Absolute Maximum Operating Temperature Range	T <sub>a</sub>	—	0	—	+85 (3)	°C	
Storage Temperature	T <sub>s</sub>	—	-40	—	+125	°C	
Weight	—	Vertical/Horizontal	—	53/66	—	grams	

- Notes** (1) ISR-will operate down to no load with reduced specifications. Please note that this product is not short-circuit protected.  
 (2) The PT7750 series can be easily paralleled with one or more of the PT7747 Current Boosters to provide increased output current in increments of 15A  
 (3) See safe operating area curves or contact the factory to determine the appropriate derating.

**Output Capacitors:** The PT7750 series requires a minimum output capacitance of 2000 $\mu$ F for proper operation. Do not use Oscon type capacitors. The maximum allowable output capacitance is (42,000 + V<sub>out</sub>) $\mu$ F for the PT7751, (96,000 + V<sub>out</sub>) $\mu$ F for the PT7756, or 15,000 $\mu$ F, whichever is less.

**Input Filter:** An input inductor is optional for most applications. The input inductor must be sized to handle 9ADC with a typical value of 1 $\mu$ H. The input capacitance must be rated for a minimum of 8.0 Arms of ripple current when operated at maximum output current and maximum output voltage. Contact an applications engineer for input capacitor selection for applications at other output voltages and output currents.

# PT7750 Series

15 Amp 24V Input "Big Hammer III"  
Programmable ISR

## Programming Information

				PT7751		PT7756	
				VID4=1	VID4=0	VID4=1	VID4=0
VID3	VID2	VID1	VID0	Vout	Vout	Vout	Vout
1	1	1	1	2.5V	4.1V	6.6V	9.8V
1	1	1	0	2.6V	4.2V	6.8V	10.0V
1	1	0	1	2.7V	4.3V	7.0V	10.2V
1	1	0	0	2.8V	4.4V	7.2V	10.4V
1	0	1	1	2.9V	4.5V	7.4V	10.6V
1	0	1	0	3.0V	4.6V	7.6V	10.8V
1	0	0	1	3.1V	4.7V	7.8V	11.0V
1	0	0	0	3.2V	4.8V	8.0V	11.2V
0	1	1	1	3.3V	4.9V	8.2V	11.4V
0	1	1	0	3.4V	5.0V	8.4V	11.6V
0	1	0	1	3.5V	5.1V	8.6V	11.8V
0	1	0	0	3.6V	5.2V	8.8V	12.0V
0	0	1	1	3.7V	5.3V	9.0V	12.2V
0	0	1	0	3.8V	5.4V	9.2V	12.4V
0	0	0	1	3.9V	5.5V	9.4V	12.6V
0	0	0	0	4.0V	5.6V	9.6V	12.8V

Logic 0 = Pin 12 potential (remote sense gnd)  
Logic 1 = Open circuit (no pull-up resistors)  
VID3 and VID4 may not be changed while the unit is operating.

## Ordering Information

PT7751□ = 2.5 to 5.6 Volts  
PT7756□ = 6.6 to 12.8 Volts

(For dimensions and PC board layout, see Package Styles 1000 and 1010.)

## PT Series Suffix (PT1234X)

### Case/Pin Configuration

Vertical Through-Hole	N
Horizontal Through-Hole	A
Horizontal Surface Mount	C

# TYPICAL CHARACTERISTICS

Efficiency vs Output Current (@Vin=+24V)

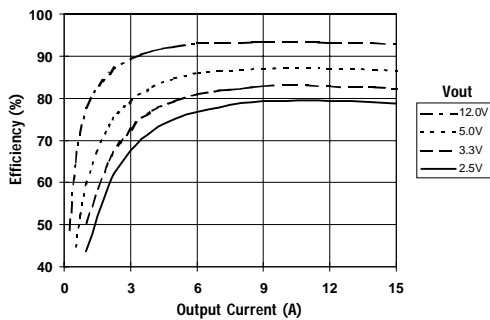

Output Ripple vs Output Current (@Vin=+24V)

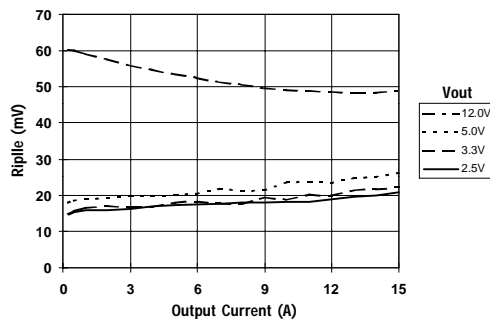

Power Dissipation vs Output Current (@Vin=+24V)

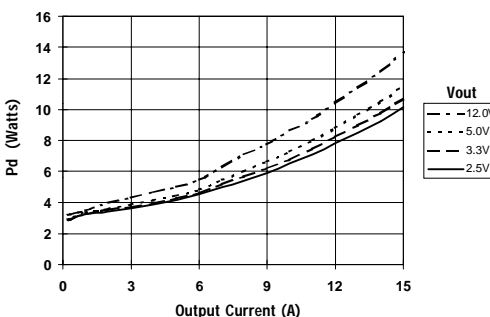

PT7751 Safe Operating Area (@Vin=+24V, Over V<sub>o</sub> Range)

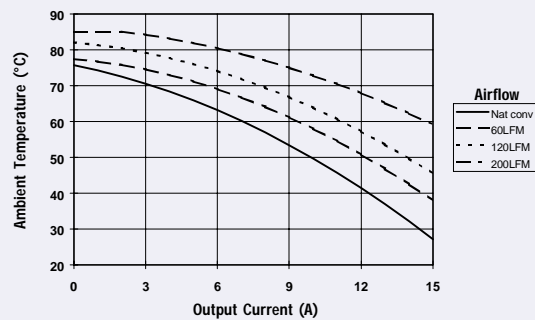

PT7756 Safe Operating Area (@Vin=+24V, Over V<sub>o</sub> Range)

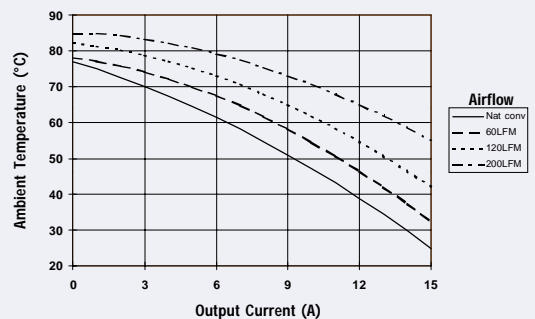

Note: SOA curves represent operating conditions at which internal components are at or below manufacturer's maximum rated operating temperatures.

## Pin-Coded Output Voltage Adjustment on the “Big Hammer III” Series ISRs

Power Trends PT7750 series ISRs incorporating pin-coded voltage control, use pins 1, 2, 3, 4, & 6 to adjust the output voltage. The control pins are identified VID0 - VID4 respectively. When the control pins are left open-circuit, the ISR output will regulate at its factory trimmed output voltage. Each control pin is internally connected to a precision resistor, and when grounded increases the output voltage by a set amount. The internal resistors are binary code weighted, allowing the output voltage of the ISR to be programmed as a function of a binary code. VID0 represents the LSB, and VID4 the MSB (or range change bit). The output voltage ranges offered by these regulators are compatible with some microprocessors, and provide a convenient method of output voltage selection for many other applications. Refer to Figure 1 below for the connection schematic, and the PT7750 Data Sheet for the programming code information.

### Notes:

- The programming convention is as follows:-
  - Logic 0: Connect to pin12 (Remote Sense Ground).
  - Logic 1: Open circuit/open drain (See notes 2, & 4)
- Do not connect pull-up resistors to the voltage programming pins.
- To minimize output voltage error, always use pin 12 (Remote Sense Ground) as the logic “0” reference. While the regular ground (pins 13-19) can also be used for programming, doing so will degrade the load regulation of the product.
- If active devices are used to ground the voltage control

pins, low-level open drain MOSFET devices should be used over bipolar transistors. The inherent  $V_{ce(sat)}$  in bipolar devices introduces errors in the device's internal divider network. Discrete transistors such as the BSS138, 2N7002, IRLML2402, or the 74C906 hex open-drain buffer are examples of appropriate devices.

### Active Voltage Programming:

Special precautions should be taken when making changes to the voltage control program code while the unit is powered. It is highly recommended that the ISR be either powered down or in standby. Changes made to the program code while  $V_{out}$  is enabled induces high current transients through the device. This is the result of the electrolytic output capacitors being either charged or discharged to the new output voltage set-point. The transient current can be minimized by making only incremental changes to the binary code, i.e. one LSB at a time. A minimum of 100 $\mu$ s settling time between each program state is also recommended. Making non-incremental changes to VID3 and VID4 with the output enabled is discouraged. If they are changed, the transients induced can overstress the device resulting in a permanent drop in efficiency. If the use of active devices prevents the program code being asserted prior to power-up, pull pin 5 (STBY) to the device GND during the period that the input voltage is applied to  $V_{in}$ . Releasing pin 5 will then allow the device output to execute a soft-start power-up to the programmed voltage. For more information on the use of the Standby function, consult the related application note, “Using the Standby Function on the ‘Big Hammer III’ Programmable ISR Series.”

Figure 1

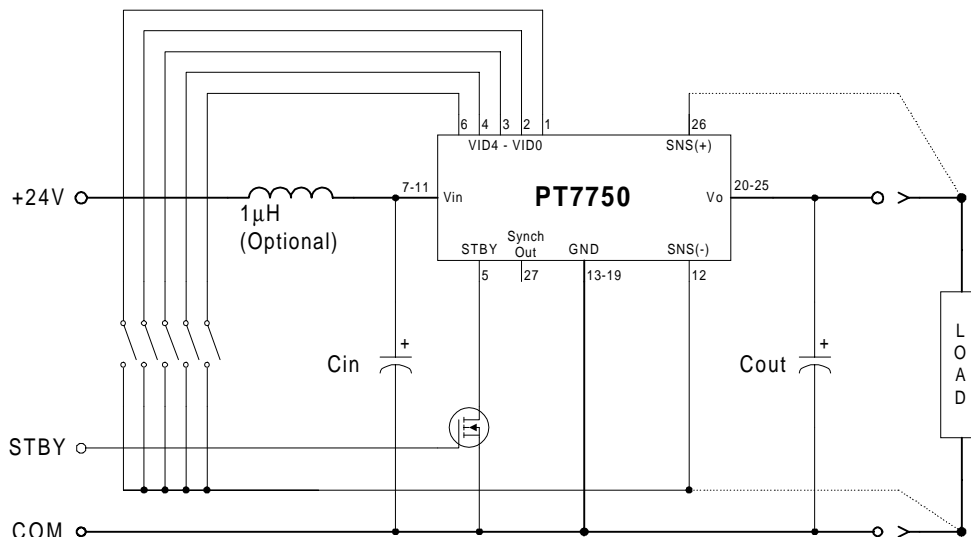

## Using the Standby Function on the PT7750 “Big Hammer III” Programmable ISRs

For applications requiring output voltage On/Off control, the PT7750 “Big Hammer” ISRs incorporate a standby function<sup>1</sup>. This feature may be used for power-up/shut-down sequencing, and to change the output voltage while input power is applied. *See related notes:* “Pin-coded Output Voltage Adjustment on the ‘Big Hammer III’ Series ISRs.”

The standby function is provided by the *STBY\** control, pin 5. If pin 5 is left open-circuit the regulator operates normally, providing a regulated output whenever a valid supply voltage is applied to  $V_{in}$  (pins 7-11) with respect to GND (pins 13-19). Connecting pin 5 to ground<sup>2</sup> will set the regulator output to zero volts<sup>3</sup>. This places the regulator in standby mode, and reduces the input current to typically 30mA (50mA max). If a ground signal is applied to pin 5 prior to power-up, the regulator output will be held at zero volts during the period that input power is applied.

The standby input must be controlled with an open-collector (or open-drain) discrete transistor (See Figure 1). Table 1 gives the threshold requirements.

**Table 1 Inhibit Control Threshold<sup>2</sup>**

Parameter	Min	Max
Disable ( $V_{IL}$ )	-0.1V	0.3V

### Notes:

1. The Standby/Inhibit control logic is similar for all Power Trends’ modules, but the flexibility and threshold tolerances will be different. For specific information on this function for other regulator models, consult the applicable application note.
2. The Standby input on the PT7750 regulator series must be controlled using an open-collector (or open-drain) discrete transistor. *Do Not* use a pull-up resistor. The control input has an open-circuit voltage of about 1.5Vdc. To set the regulator output to zero, the control pin must be “pulled” to less than 0.3Vdc with a low-level 0.1mA sink to ground.
3. When placed in the standby mode, the regulator output discharges the output capacitance with a low impedance to ground. If an external voltage is applied to the output, it will sink current and possibly over-stress the part.
4. The turn-off time of  $Q_1$ , or rise time of the standby input is not critical on the PT7750 series. Turning  $Q_1$  off slowly, over periods up to 100ms, will not affect regulator operation. However, a slow turn-off time will increase both the initial delay and rise-time of the output voltage.

**Figure 1**

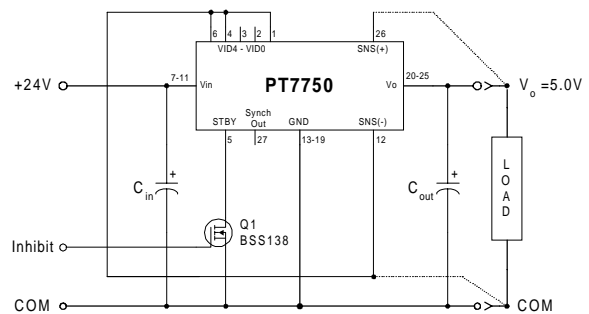

**Turn-On Time:** Turning  $Q_1$  in Figure 1 off, removes the low-voltage signal at pin 5 and enables the output. Following a brief delay of 8-18ms, the output voltage of the PT7750 series regulators rise to full regulation within 20ms<sup>4</sup>. Figure 2 shows the typical output voltage waveform of a PT7751 following the prompt turn-off of  $Q_1$  at time  $t = 0$  secs. The output voltage in Figure 1 is set to 5.0V by connecting VID0 (pin 1), VID3 (pin 4), and VID4 (pin 6) to the Remote Sense Gnd (pin 12)<sup>4</sup>. The waveform in Figure 2 was measured with a 24V input source voltage, and 10A resistive load.

**Figure 2**

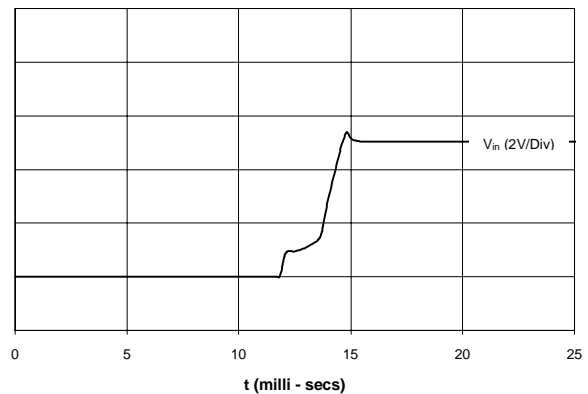

<sup>4</sup> Consult the data sheet for details on other VID codes.